

Series 1100



HYDRAULIC CABLE WINCHES

The rugged construction and versatility of the **1100 Series** makes it adaptable to a wide range of applications. 1100 Series direct drive winches are used for industrial pulling and hoisting applications including small cranes, rear load waste packers, drill rigs, fishing boats, marine craft, mining and logging operations, flat bed trailers, air freight pullers, rear of cab and front mounting on ½ to 1 ½ ton trucks.

1100 Series shown

*"Quality Since
1910"*



**UP TO 12,000 LBS.
CAPACITY**

Bloom Hydraulic Cable Winches – Standard Features

- GEAR CASE** - Special low profile design. Made of high strength cast iron. Completely sealed for oil enclosed operation and to keep dirt out.
- WORM SHAFT** - One piece alloy steel hardened and ground for extra durability.
- WORM GEAR** - High tensile aluminum-nickel alloy bronze. Optimum lead and pressure angles transmit maximum power to the drum.
- GEAR RATIO** - 20:1 standard, 10:1, 27:1, and 40:1 optional ratios provide optimum efficiency in power and speed.
- BEARINGS** - Worm gear and worm shaft run on tapered roller bearings. Outer end housing has a sealed ball bearing.
- DRUM SHAFT** - 1-1/2" diameter heat -treated alloy steel minimum tensile strength 150,000 psi.
- CABLE DRUM** - Tough all steel construction resists breakage or warping.

CAUTION:

This winch model does not include any kind of holding brake. If your application requires a holding brake choose 1100H series winches with hydraulic fail-safe brake.



BLOOM

Manufacturing Inc.

Winch Division

*Lifting
Pulling
Hoisting*

www.bloommfg.com

"Custom Engineered Solutions"

Toll Free Number: 1-800-394-1139

1443 220th Street., Independence, Iowa 50644 • FAX: 319-827-1140 • PHONE: 319-827-1139

1100 Series

Model Selection from Performance Data



*"Quality Since
1910"*

MODEL EXAMPLE: 11-E-L8-20

Gear Case and _____

Shaft Designation

11 = 1100 Series with 1-1/2" Drum Shaft

Hydraulic Motor Designation _____

A, B, C, DD, E, G, 4.9, 6.2, 8.0, 9.6, 11.9

IS Input Shaft

Drum Sizes _____

S8, L8 & XL10

Gear Ratios

10:1, 20:1, 27:1, 40:1

- (10) Indicates winch series. "11" indicates a 1100 Series winch. Both are manufactured with an 1-1/2" drum.
- (E) Designates hydraulic motor. Motor size is determined from motor performance charts. All motors have 7/8-14 SAE O-ring ports. To order a mechanically driven winch with 1" input shaft use designation "IS". Mechanical winches are available with 1-1/2" shaft models only.
- (L8) Select drum size from chart below:

DRUM CAPACITY

CABLE DIAMETER (IN.)	1/4	5/16	3/8	7/16	1/2
DRUM "S8" CAPACITY (FT.)	260	160	105	75	55
DRUM "L8" CAPACITY (FT.)	390	240	160	110	80
DRUM "XL10" CAPACITY (FT.)	840	550	340	250	170

- (20) Indicates gear ratio. 20:1 is standard. 10:1, 27:1, and 40:1 are also available.

Special Note.

1100 Series winches are available only in low profile mounting - the "LP" designation is not required. However, it is necessary on all low profile winches to specify whether the winch is to be supplied "with angles" or "less angles".

Series 1100



Bloom Hydraulic Cable Winches Model Selection from Performance Data

"Quality Since 1910"

10:1 RATIO (optional)

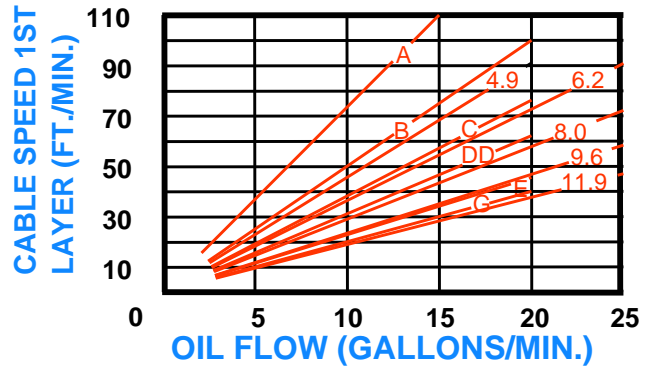
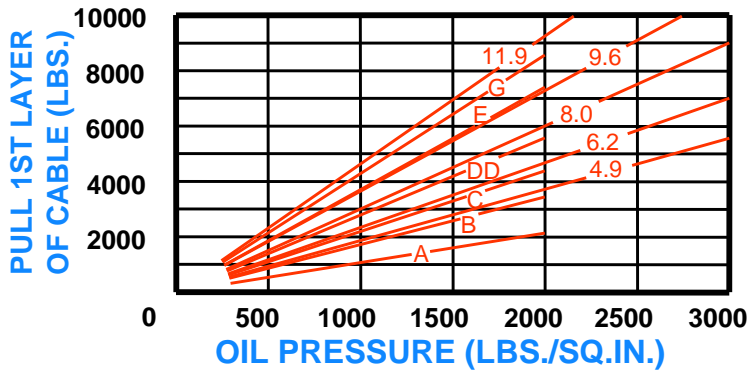

20:1 RATIO (standard)

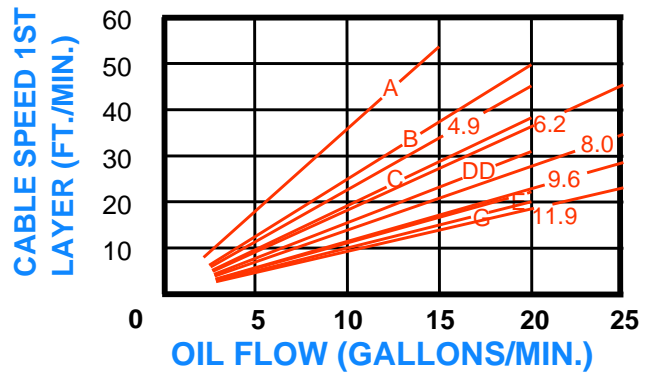
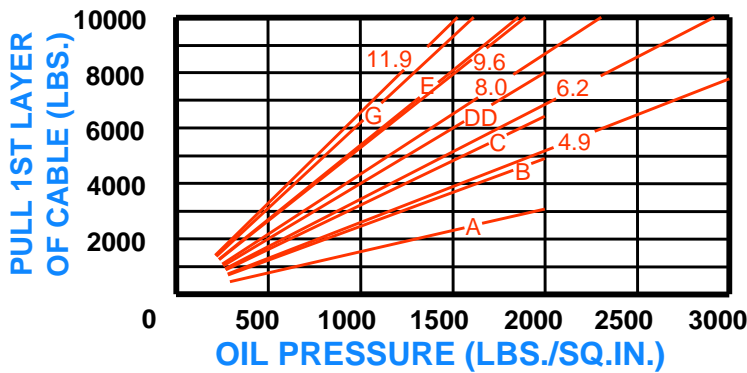

27:1 RATIO (optional)

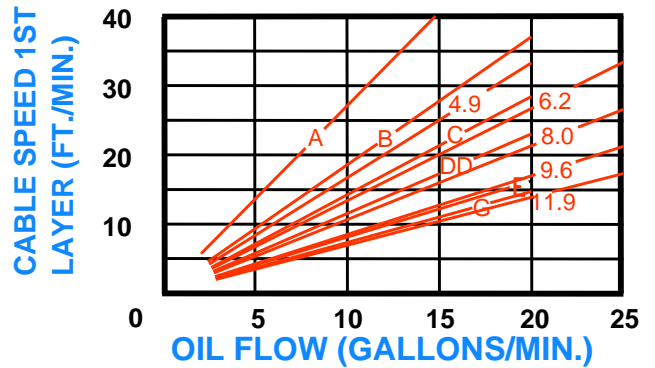
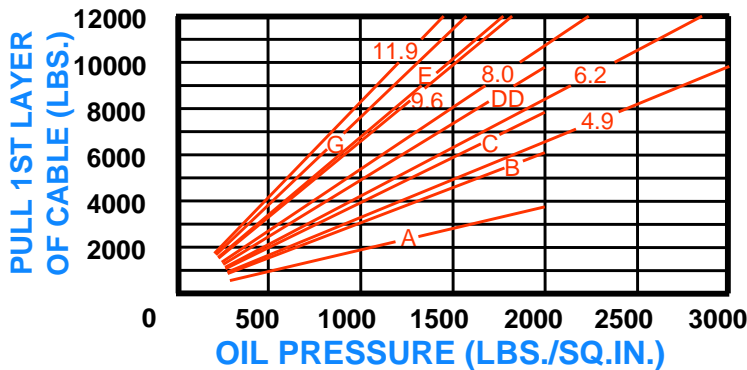

40:1 RATIO (optional)

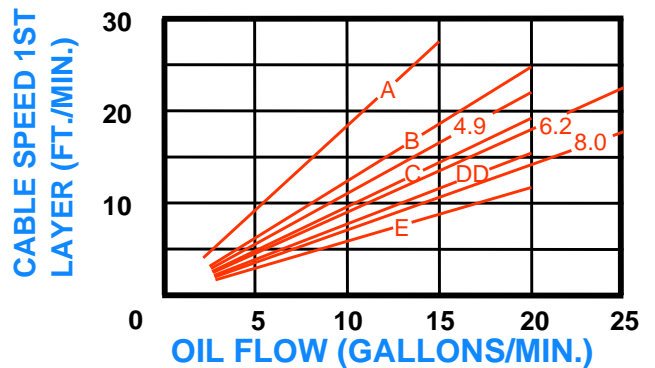
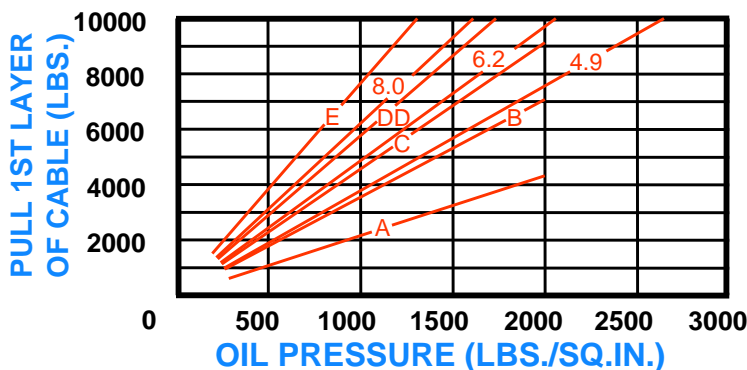



Dimensional Drawings

1100 Series With S8 and L8 Drum
Low Profile Model - Direct Drive

"Quality Since
1910"

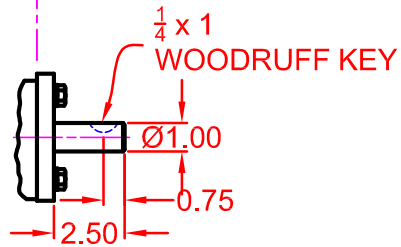
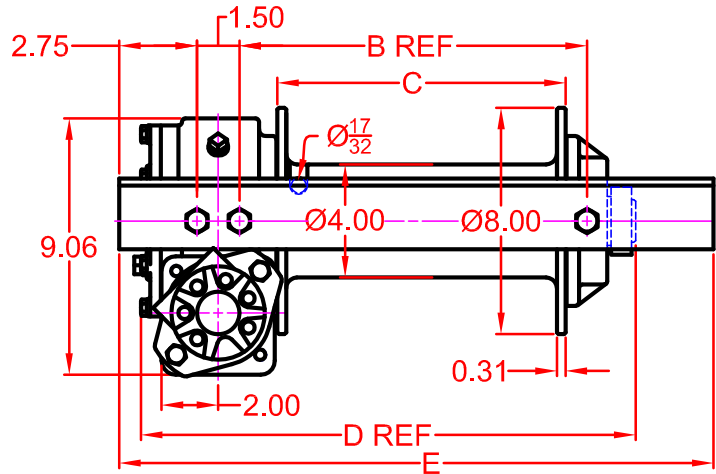
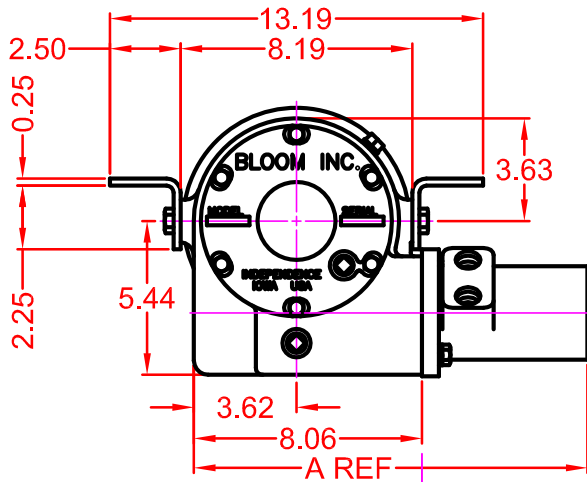

INPUT SHAFT MODEL

MOTOR DESIGNATION	A	B	C	DD	E	G	4.9	6.2	8.0	9.6	11.9
A DIMENSION	13.28	13.43	13.55	13.68	13.90	14.03	15.32	15.50	15.75	15.75	16.02

DRUM DESIGNATION	WINCH DIMENSION			
	B	C	D	E
S8	9.25	7.19	14.44	18.00
L8	12.25	10.19	17.44	21.00



**"Quality Since
1910"**

Dimensional Drawings

**1100 Series With XL10 Drum
Low Profile Model - Direct Drive**

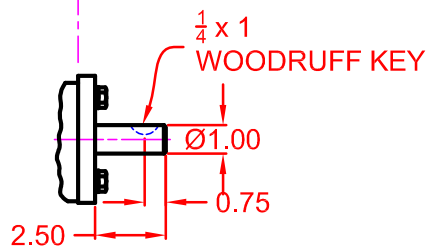
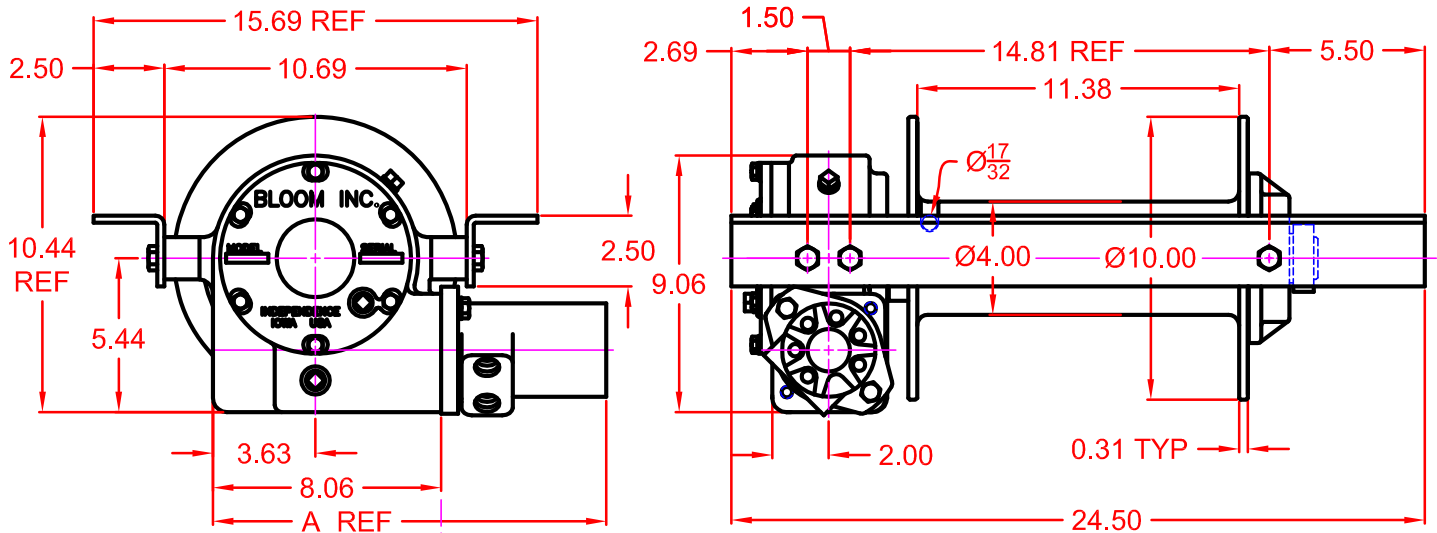

INPUT SHAFT MODEL

MOTOR DESIGNATION	A	B	C	DD	E	G	4.9	6.2	8.0	9.6	11.9
A DIMENSION	13.28	13.43	13.55	13.68	13.90	14.03	15.32	15.50	15.75	15.75	16.02

CABLE DIAMETER (IN.)	1/4	5/16	3/8	7/16	1/2
DRUM "XL10" CAPACITY (FT.)	840	550	340	250	170

Correct choice of Directional Control Valves for Bloom Winches

Tandem Center Spool Valve – Work Ports are **blocked** in neutral position

Use on all winches that use motor only to hold load.

*Winches require ridged mounting plate.
See owner's manual for information about proper mounting plate thickness or call Bloom Sales Engineer at factory

WARNING!

Goods are not intended for use in the moving or lifting of persons!

The winches described herein are neither designed nor intended for use or application to equipment used in the lifting or moving of persons and it is understood that all such use shall be at the sole risk of the user.

The cable clamps on winches are not designed to hold rated loads. A minimum of 5 wraps of cable must be left on drum barrel to guarantee holding of rated load.

Applications of winch where life would be endangered by any event are not recommended.



BLOOM Manufacturing Inc.

Winch Division

1443 220th Street,, Independence, Iowa 50644

FAX 319-827-1140 PHONE 319-827-1139

www.bloommfg.com