

Disassembly Instructions 1200W & 1200WC Series Winches



- 1) Drain oil from gear case.
- 2) Loosen set screw in eccentric collar, then turn collar counter-clockwise with punch to release it from bearing and shaft.
- 3) Remove end housing (direct drive) or clutch housing (clutch drive) assembly from drum shaft.
- 4) Remove retaining ring and drum from shaft.
- 5) Remove phenolic friction block & spring (clutch model) or wear block (direct drive) from gear case.
- 6) **Brake & Motor Removal** (Section A)
 - a) Loosen jam nuts and locking nuts to remove brake line.
 - b) Remove (4) 5/16" x 2-3/4" hex head cap screws. Remove counterbalance valve.
 - c) Loosen and remove (2) M12 x 30 mm hex head cap screws. Remove motor from back of brake housing.
 - d) Loosen and remove (2) 5/16" x 1-1/2" hex head cap screws from brake housing. Remove brake housing from winch.
- 7) Remove worm shaft and bearings from gear case.
- 8) Remove gear case cover.
- 9) Remove bronze gear and drum shaft as a unit being careful not to damage shaft seal.

Note: Bronze gear is press fit on shaft. **DO NOT** remove unless absolutely necessary.

Section A

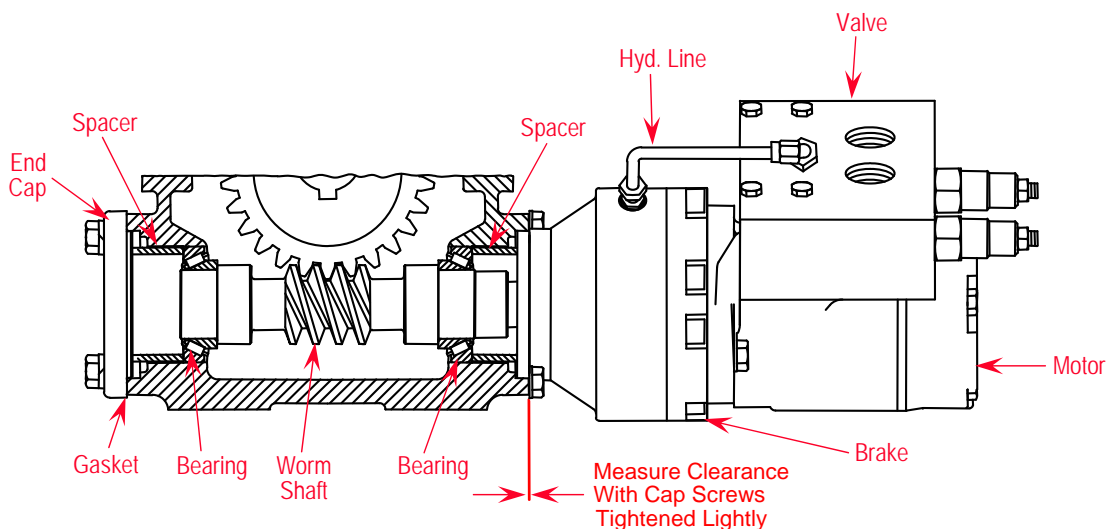

Assembly Instructions 1200W & 1200WC Series Winches

- 1) Clean gear case and all parts thoroughly, inspect oil seal and replace if worn or scored.
- 2) If bronze gear has been removed from shaft, care should be used to press the gear onto the shaft squarely. Press gear and keys onto shaft simultaneously. Locate end of gear hub (the set screw side) 3/4" from the shaft end (Section B).
- 3) If removed install oil seal and bearings. Install drum shaft assembly into gear case carefully to prevent damage to the shaft seal.
- 4) Bolt cover to gear case without shim gaskets. Tighten the screws lightly and evenly. Measure clearance between cover and gear case with feeler gage and remove cover. For proper bearing pre-load, install shim gaskets (red - .002", blue - .005", brown - .010") onto cover as required with a thickness that is .003" to .005" less than the measurement.
Re-bolt cover securely. Check bearing thrust by turning drum shaft. Shaft must turn freely but with just a slight amount of resistance.

Section B

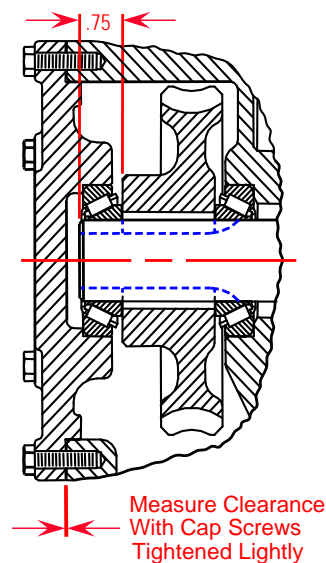

Do Not Use Hammer To Install Bronze Gear Onto Shaft

- 5) Install worm shaft into gear case. Install bearing cones such that the large end of each cone seats against each worm shoulder (Section C). Install bearing cups and thrust spacers. Spacer on end cap side is 1.21 wide. Install (2) .010 brown gaskets and end cap with (4) 7/16"-14NC x 1-1/2" HT cap screws.

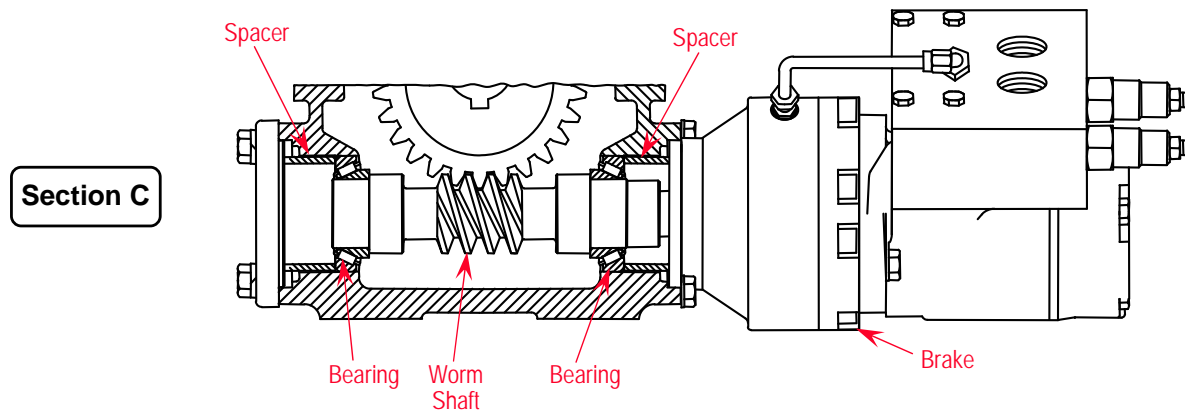

6) Brake & Motor Assembly

- Install key into brake output shaft. Make sure thrust spacer is against bearing. Bolt brake housing to gear case without shim gaskets with (2) 7/16" x 1-1/2" socket head cap screws. Tighten the screws lightly and evenly. Measure clearance with a feeler gage and remove brake housing (Section B). For proper bearing pre-load, install shim gaskets (red - .002", blue - .005", brown - .010") as required with a thickness that is .003" - .005" less than the measurement. Re-bolt brake housing securely.
- Carefully Install hydraulic motor to brake housing using (6) (W-239) brown motor gasket and (2) M12 x 30 mm hex head cap screw.
- Bolt double counterbalance valve to motor manifold bearing end cap using O-Rings provided and (4) 5/16" x 2-3/4" hex head cap screws.
- Install brake line into 7/16" fitting on counterbalance valve and brake (If installing a new brake line it may be necessary to cut brake line to fit). Tighten jam nuts on male elbows to hold in place. Tighten locking nuts on fittings to hold brake line in place. Turn nut only until tapered split ring starts to come through the back side or the brake line side of the nut.

- 7) DIRECT DRIVE: Grease drum shaft with multi-purpose lithium grease or equivalent and install wear block and drum. Install retaining ring. Place end housing assembly on drum shaft and slide toward drum until there is about 1/16" clearance between housing and drum. Place collar on bearing being sure it is properly seated on bearing eccentric. Turn clockwise with punch until bearing and shaft are held tight, then tighten set screw.

CLUTCH DRIVE: Grease drum shaft with multi-purpose lithium grease or equivalent. Install spring and phenolic friction block in gear case. Place drum on shaft and install retaining ring to hold drum against friction block. If yoke is not already securely fastened to clutch handle shaft, refer to "Replacement of Clutch Handle and Yoke" page. Grease clutch dog groove and place on drum shaft with spring and washer. Install clutch housing assembly on drum shaft placing yoke in clutch dog groove. Slide clutch housing toward drum until there is about 1/16" clearance between housing and drum. Place collar on bearing being sure it is properly seated on bearing eccentric. Turn collar clockwise with punch until bearing and shaft are held tight, then tighten set screw. The dog is designed to engage fully into the drum when the spring-loaded clutch handle pin is in the hole closest to the drum. Check that the drum turns freely when the clutch handle pin is in the hole farthest from the drum. Refer to "Replacement of Clutch Handle and Yoke" page.

- 8) Base Mounted: Fill gear case with (1) pint, All Other Mounting Positions: Fill gear case with (2) pints **Bloom ULLTRA-LUBE NO. 601 TRANS-WORM GEAR OIL**; available from Bloom in pints or quarts. The hardened steel worm shaft must run in oil. For emergency situations when **Bloom ULLTRA-LUBE NO. 601** is not immediately available, use Phillips 66 Company SAE grade 80W90 superior multi-purpose gear oil (Phillips 80W90 SMP) meeting API classification GL-5 or equivalent competing brand. Continuous use of oil other than **Bloom ULLTRA-LUBE NO. 601** or Phillips 80W90 SMP may shorten the life of the gears. DO NOT mix **Bloom ULLTRA-LUBE NO. 601** or Phillips 80W90 SMP with more than 50% of any other kind of oil.